

Noise Inspector: Making Noise Visible

Software development
Test stand development
System supplier

Products

Intensity Inspector
Signal Inspector

Noise Inspector



Undesired noise sources become visible

Our acoustic camera, the **Noise Inspector**, rules out any insecurity when determining noise sources. Thanks to innovative technology, the sound emission is converted to images; sound sources hitherto hidden become visible and can therefore be avoided effectively.



The exact determination of noise sources which cannot be perceived by our senses alone is one of the decisive success factors for product development. What noise is disturbing, where does it come from and, more important, how can it be quickly and effectively rectified? Examination methods used so far such as sound intensity measurement are time-consuming and cost-intensive.

The Noise Inspector from CAE is completely different.

The **Noise Inspector** is a modular, extremely flexible acoustic camera with which you can minimise development times for your products and increase your competitive ability. Due to the exact determination of causes and clear visualisation of the noise sources, you are placed in a position to react fast. The system guarantees precise and uncomplicated determination of acoustic sources, also convincing through its low costs.

How the Noise Inspector functions:

As with a camera, virtual images of the sound sources are generated at any focus level desired. As opposed to the optical camera, the focus level can be moved freely. Acoustic images can be calculated at various depths of focus without making new measurements. A huge advantage with regard to your time consumption and work input. The system is mobile, fast and supplies first rate results.



Acoustic camera details

The Noise Inspector consists of:

- A flexible microphone array in its standard design or also as a laboratory aerial whose geometry you can adapt individually to the application required in order to achieve the best possible physical results.
- User-friendly software based on **LabVIEW**
- National Instruments PXI hardware with high performance ICP data acquisition modules
- Various analysis options using versatile algorithms such as:

- **Beam forming**
- **Acoustic holography**
- **Modern CAE-developed algorithms**
- **User-defined algorithms**

How to use the Noise Inspector:

- Erect the mobile Noise Inspector system
- Record data
- Fast identification of the noise searched for in the sonogram
- Acoustic images or videos are developed from these noises by mouse click
- Listen to noise sources found with the "Local sound module" to verify the source of the noise
- Further little features help during analysis



Modular laboratory aerial enables the most varied array sizes and areas of use.

Noise Inspector application options for universities

The **Noise Inspector** is well suited for applications at universities. The software which is based on LabVIEW is user-friendly. Thanks to the **user algorithm**, an externally used algorithm, it offers universities and institutes versatile application options such as:

- Introduction to array sensor systems
- The use of simple algorithms in education
- Research for complex analytical methods

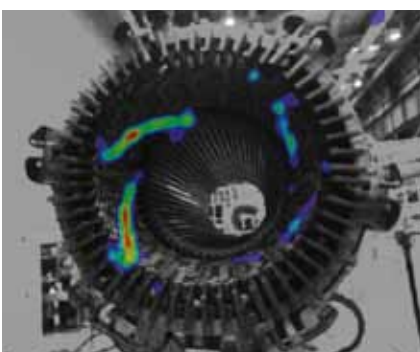

Measurement during a high voltage test

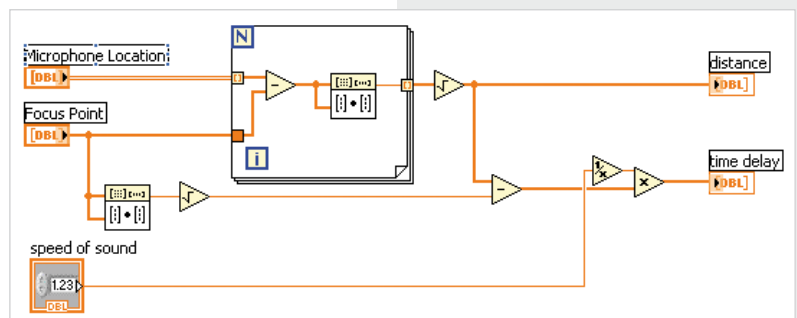

Development with LabVIEW

The Noise Inspector software achieves:

- Assistant for the definition of various microphone distributions such as 2D-linear, spiral, ring
- Performance test for the microphone arrangement selected by simulation with virtual sources
- Front end setup assistant
- Optimum adaptation to the application, frequency range and required geometric resolution
- Microphone calibration
- Data recording with online display
- Automatic alignment of photo and acoustic image with software-supported reference measurement
- Image recording with fixed installed system camera or import of JPEGs from any source desired (e.g. photo or CAD data)
- Frequency analysis and time frequency analysis (sonogram)

- Analysis using various different methods
- A, B, C and linear weighting
- Automatic evaluation of sequences in the time range(video)
- Automatic generation of Word documentation
- Replay of the local noise ("listening in")
- Acoustic videos and photos
- Easy to operate, clearly arranged user interface

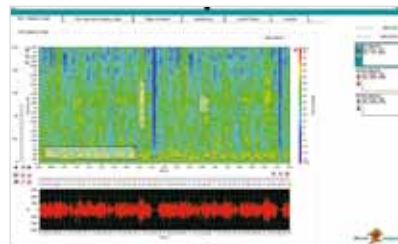
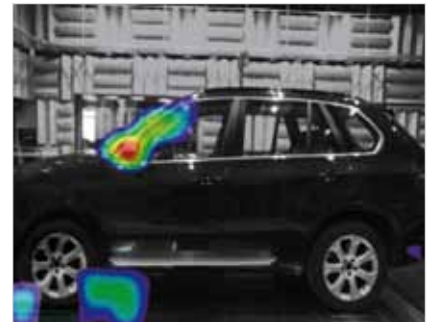

Time-frequency analysis (sonogram)

Acoustic videos and photos, Example: wind tunnel

The latest hardware components guarantee quality

CAE also banks on quality for the hardware: the versatile, high-performance PXI platform from our partner company **National Instruments** ensures you absolutely reliable measurement data recording.

National Instruments is one of the leading software and hardware producers and offers a comprehensive range for all application types. From portable applications via embedded systems to stationary applications. There are good reasons why these products are used worldwide by scientists and engineers for establishing systems.

PCI eXtensions for Instrumentation (abbreviated PXI) is a current, high-performance standard technology for measurement and automation which is highly flexible.

Your advantage:

By using these standard components and their easy handling, you profit from low costs.

For the **Noise Inspector** we recommend, dependent on the system expansion level, PXI chassis with 8, 14 or 18 slots. For example, the PXI 1042Q 8 slot chassis. As a standard, the **Noise Inspector** supports the DAQ cards PXI4472 and PXI 4496/98.



PXI card 4472



PXI card 4496/98



Software development
Test stand development
System supplier

Products

Intensity Inspector
Signal Inspector

Noise Inspector

Flexible in every respect and nonetheless easy to use

The **Noise Inspector** is designed to enable you to adapt the system to your applications:

– Array geometry

Various frequency ranges and sizes of the objects to be examined require adaptation of the array in order to obtain meaningful acoustic images.

– Microphone selection

The environmental conditions may require the use of especially robust, temperature and weatherproof microphones. ICP microphones are connected directly by the hardware.

– Hardware components

The standard PXI/PXI express platform from National Instruments allows simple and good value scaling of the entire system.

– Software

The software administers these adaptations independently and uncomplicatedly and provides various algorithms.

– Flexible analysis options

Beam forming, acoustic holography and other algorithms in one system.

Software customised? Purchase or rent? You decide.

Please send a fax to: +49 (0) 2521 859-360

Have we awoken your interest?

I am interested in the following option:

- Customised software
- Purchasing software
- Rent software
- Engineering services

Name

Postcode / Town

Company

Road

E-mail

Telephone

Further information is also available from: www.noise-inspector.de
www.cae-systems.de

www.noise-inspector.com

CA Software und
Systems GmbH
Beckumer Straße 34
59229 Ahlen

Tel. +49 (0) 2382 964371
Fax +49 (0) 2521 859-360
www.cae-systems.de
E-mail: cae@cae-online.de

 **CAE**
Software & Systems